

DA 15-05-60

Spannungsversorgung	
Betriebsspannung	4,8-5 V.
Signalpegel	TTL level
Stromverbrauch	bei 5 Volt
Ruhestrom *	< 8 mA
Blockierstrom *	1500 mA
Eingangssignal	
Impulswiederholrate	7-20 ms
mögliche Impulslänge	0,9 – 2,1 ms
Links / Mitte / Rechts	0,9 ms / 1,5 ms / 2,1 ms
Auflösung	< 0,5 µsec.
Leistungsdaten bei 5 Volt	
max. Kurzzeit-Drehmoment *	60 Ncm
Leerlaufgeschwindigkeit *	330° / sec.
max. Stellweg (Standard)	+/- 65° = 130° gesamter Stellweg
Totband (mechanisch)	< 0,5°
Totband (elektrisch)	< 0,5 µsec.
Thermische Positionsabweichung: -20° C. to +50° C. (= Delta 70° C.)	< 0,3
Betriebstemperatur	-30° C. - +70° C.
Lagertemperatur	-35° C. - +80° C.
Material / Abschirmung / Schutzeinrichtungen	
Gehäuse	Seewasser resistentes Aluminium legierung / Hart-Coat
Spritzwasserschutz	EP 67
Salzwasserkorrosionsschutz	Standard
EMI / RFI Abschirmung	Standard
Getriebe	gehärteter Stahl
Getriebe Schutz System	Optional
Abmessungen / Gewicht	
Gehäuse Abmessungen / Gewicht	32,4 x 39,4 x 14,6 mm / 26 g ± 0,2 mm / ± 5%
Bestellnummer #	# 15-05-60

Der Aktuator ist voll programmierbar mit dem Programmier-Tool # 985

* Toleranz ± 10 %

DA 15-05-60

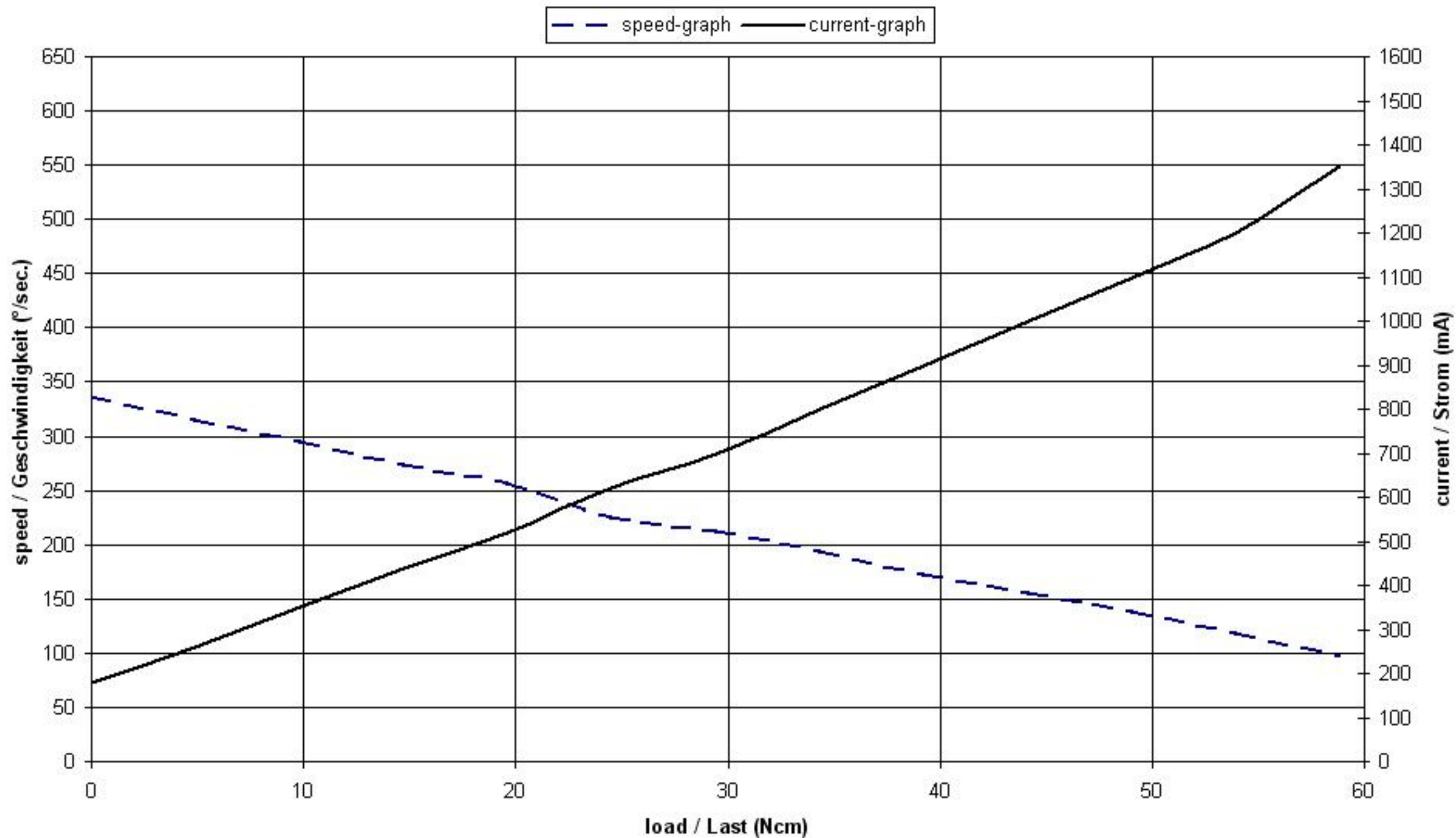

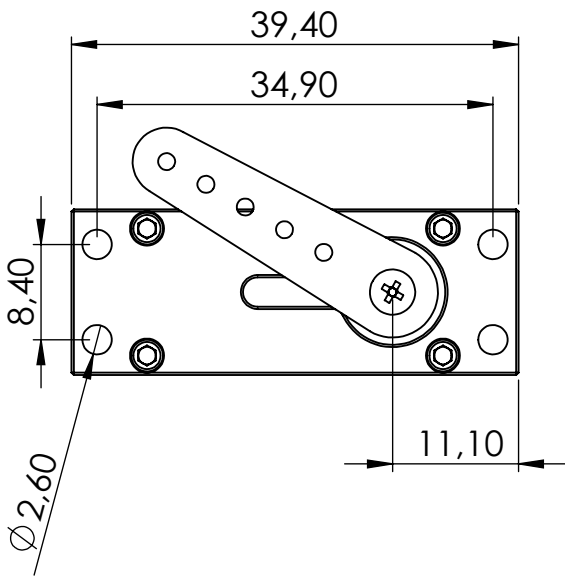
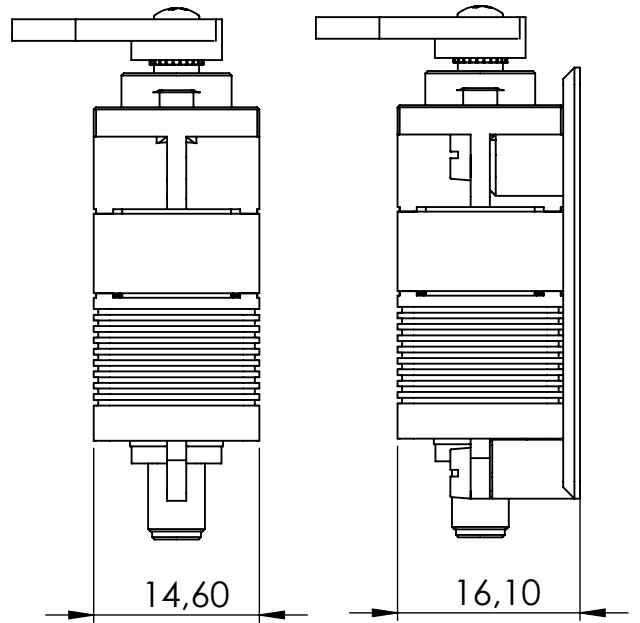
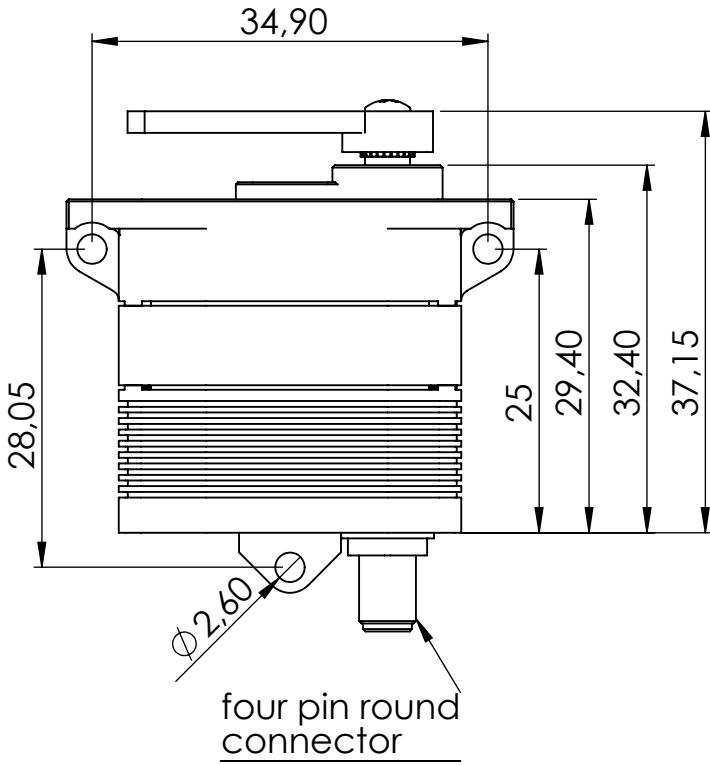

Accessories

#1521.21
alu arm - short, single sided

#1521.22
alu arm - long, single sided

#1521.31
alu mounting frame
incl. screws and washers

DA 15-05-60

scale 1,5:1
all measurements in mm

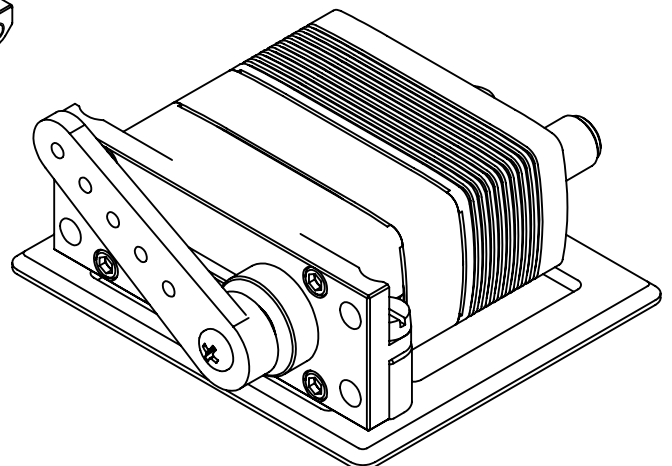

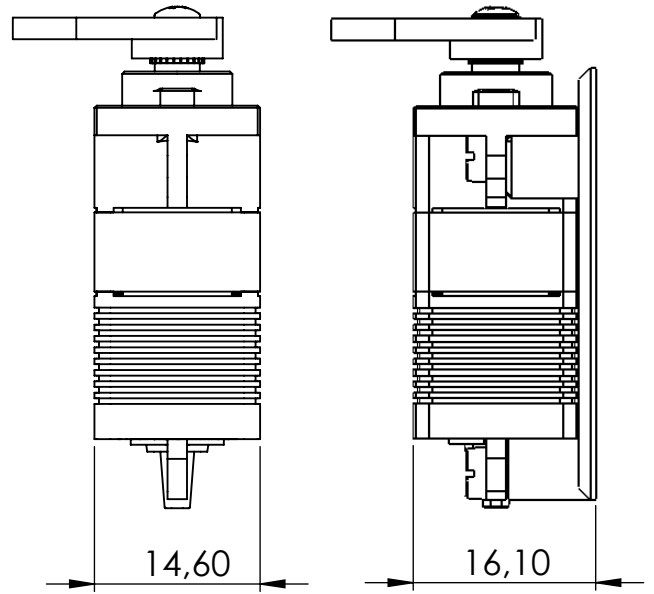
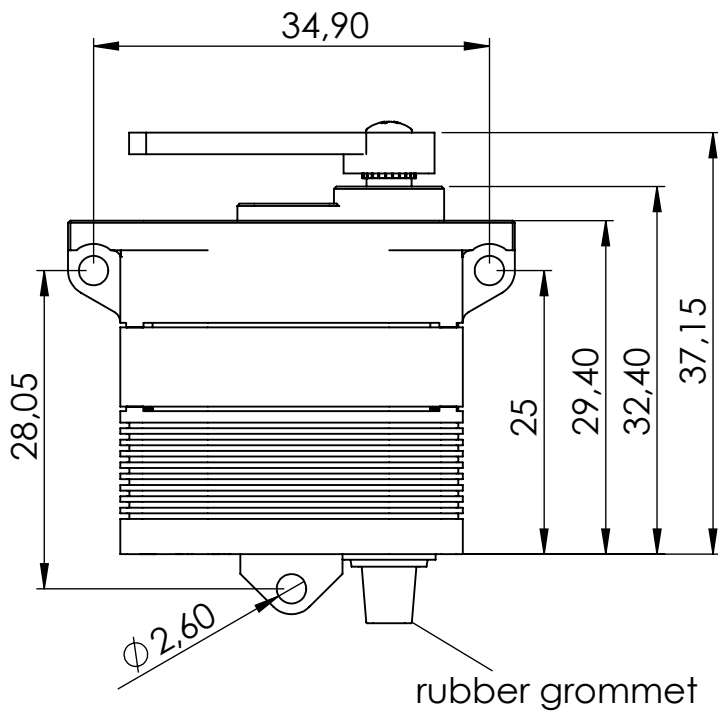

Accessories

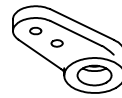
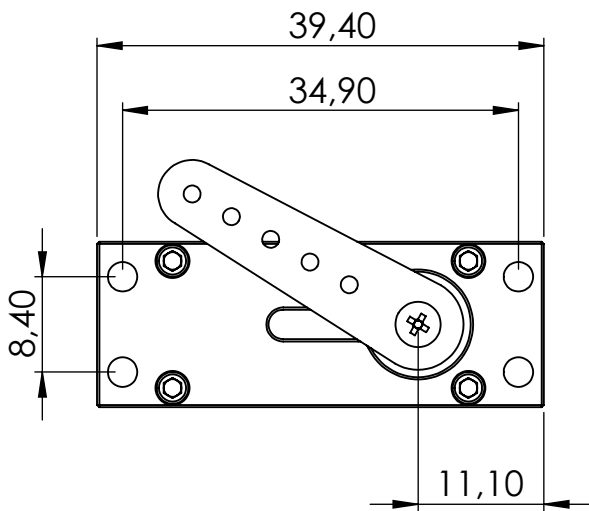

#1521.21
alu arm - short, single sided

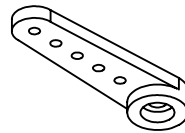

#1521.22
alu arm - long, single sided

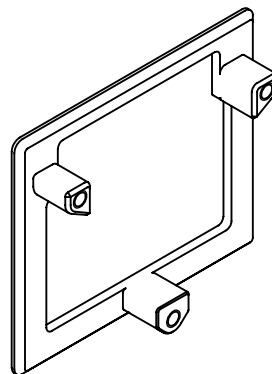

#1521.31
alu mounting frame
incl. scrwes and washers

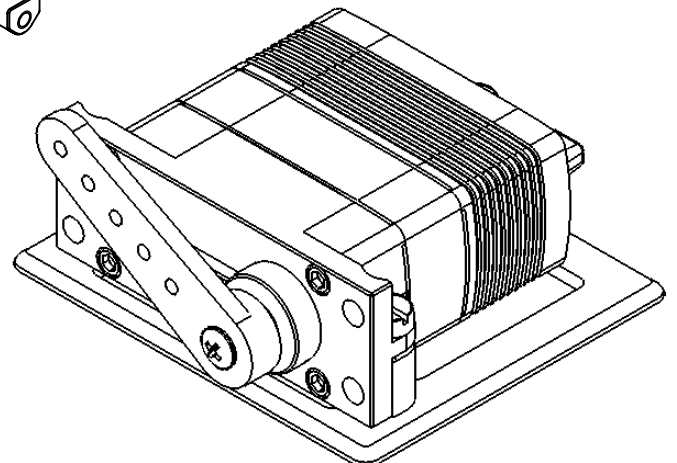

DA 15-05-60

scale 1,5:1
all measurements in mm