

DA 20-12-2515

Supply Voltage	
Operating voltage	12 Volt
Signal voltage	TTL level
Current consumption	at 12 Volt
Stand by *	< 10 mA
Stall current *	1200 mA
Input pulse	
Frame rate	7-20 ms
Valid pulse lengths	0,9 – 2,1 ms
Left / Center / Right	0,9 ms / 1,5 ms / 2,1 ms
Resolution	< 0,5 µsec.
Operating data at 12 Volts	
Peak stall torque *	160 Ncm
Continuous torque *	80 Ncm
No load speed *	210° / sec.
Max. travel angle (standard)	+/- 85° = 170° total travel
Max. travel angle (optional)	+/- 165° = 330° total travel
Deadband (mechanical)	< 0,5°
Deadband (electrical)	< 0,5 µsec.
Position error under temperature:	< 0,3 -20° C. to +50° C. (= Delta 70° C.)
Operating temperature	-30° C. - +70° C.
Max. storage temperature	-35° C. - +80° C.
Material / Shielding / Protection	
Case	Aluminium, plastic base
Splash water resistance	not available
Salt water resistance	not available
EMI / RFI shielding	not available
Gear set	hardened steel, english silver, brass
Gear protection system	Optional: ISS-System
Dimensions / Weight	
Case dimensions / Weight	41,7 x 45,6 x 20,5 mm / 88 g ± 0,2 mm / ± 5%
Item Number #	# 20-12-2515

The actuator is fully programmable using programming tool # 985

* tolerance ± 10 %

DA 20-12-2515

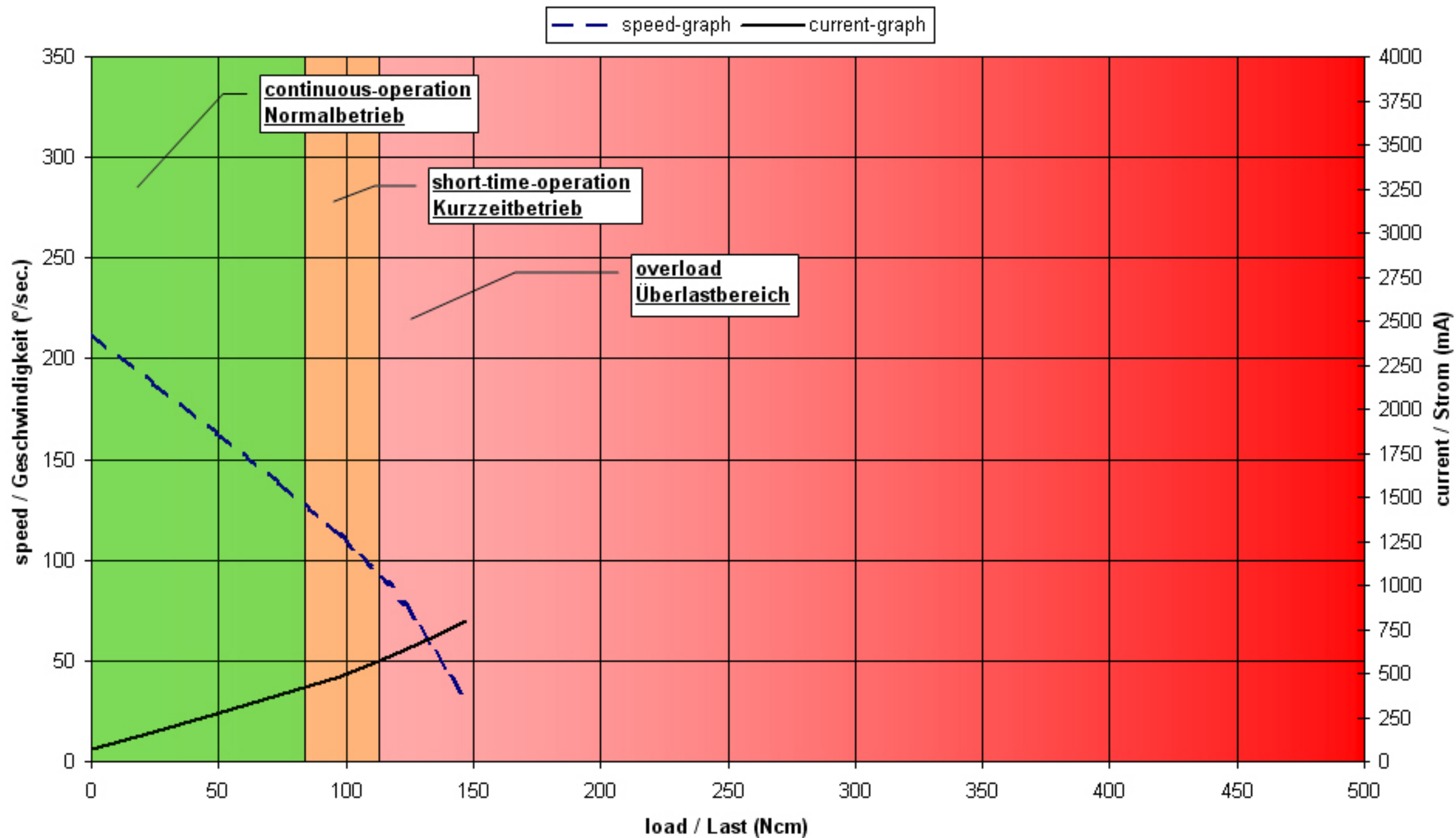

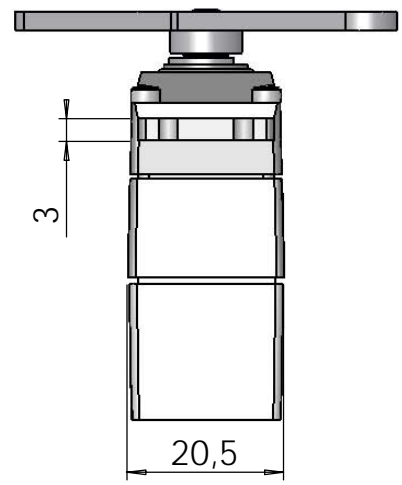
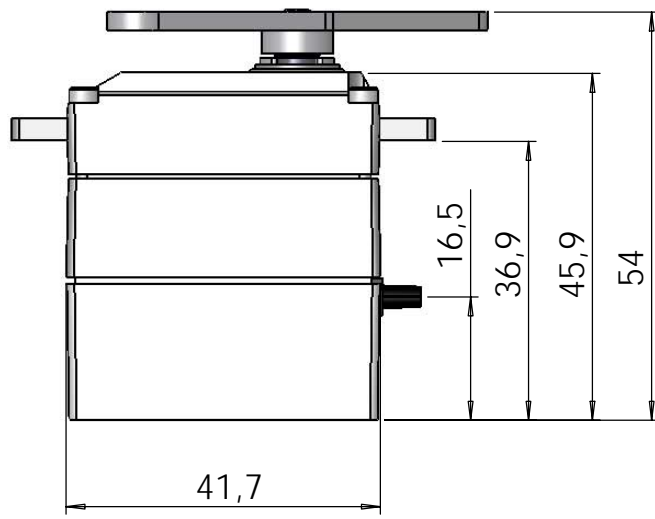

Accessories

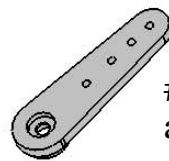
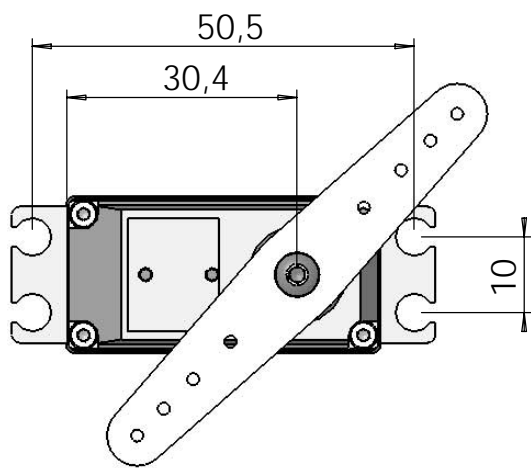

1641.21
alu arm - single sided

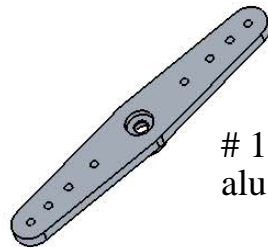

1641.20
alu arm - double sided

DA 20-12-2515

scale 1:1
all measurements in mm

